

	Width (mm)	Length (mm)	Volume (µL)
Channel A	1.4	74.83	4.67
Channel B	1.9	70.94	6.15
Channel C	2.9	70.00	9.43

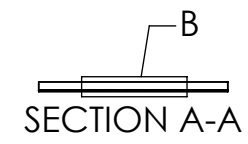

DETAIL B
SCALE 5 : 1

Zone	Rev	REVISION NOTE	Mod By	App By	App Date

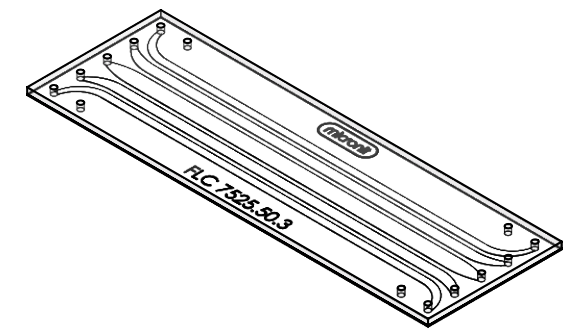

ITEM NUMBER:
03545

DRAWN BY: RN
DRAWN DATE: 14 Mar 2023
PROJECT NO:
EXT. REF.:

TITLE:
**Chip glass 75x25x1.275
Flow Cell 50 µm**

PROPRIETARY AND CONFIDENTIAL
THE INFORMATION CONTAINED IN THIS DRAWING IS THE SOLE PROPERTY OF MICRONIT BV. ANY REPRODUCTION IN PART OR AS A WHOLE WITHOUT THE WRITTEN PERMISSION OF MICRONIT BV IS PROHIBITED.

UNLESS OTHERWISE SPECIFIED:
- DIMENSIONS ARE IN MILLIMETERS
- LINEAR TOLERANCES: ± 0.1
- ANGULAR TOLERANCES: ± 5°
DO NOT SCALE DRAWING

MATERIAL:
D263 Bio

DWG NO.
42007731
SCALE: 1:1

REVISION
0
SHEET FORMAT: A4
SHEET 1 OF 1